





## FLIP TOP RECTANGLE TABLE

 NOTE: Before you begin, please make sure all parts and proper quantities are included. Any parts damaged during shipment must be reported within 24 hours of receipt. To report information regarding damages or if you have any questions, please call 800.242.2303.

 NOTE: These instructions work for all Flip Top Rectangle Tables. Product images are for illustrative purposes only and may differ from actual product.

### TOOLS NEEDED

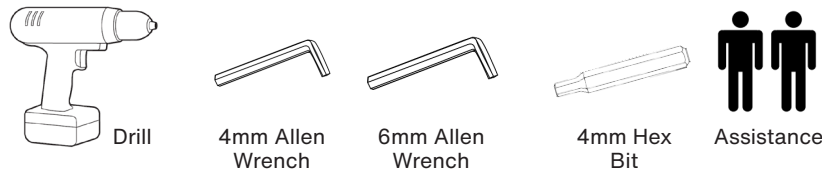



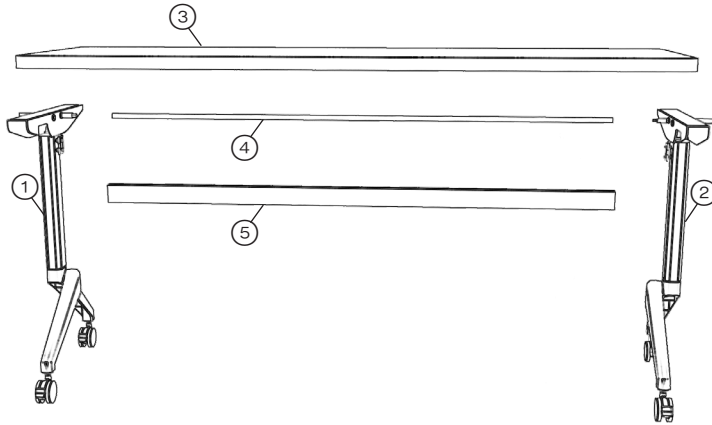



### PARTS

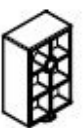
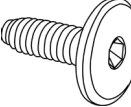

PARTS x QTY

#	DESCRIPTION x QTY
1	Leg with Casters x 1
2	Leg with Casters x 1
3	Laminate Top x 1
4	Flip Mechanism Rod x 1
5	Stretcher Bar x 1

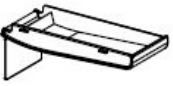
### HARDWARE x QTY

 Hardware A   M8x25 x 4 04069004	 Hardware F   Stretcher Support x 1 (Only required for tables 60" or longer) 04069008
 Hardware B   1/4" - 20x19mm JCB x 8 04069027	 Hardware G   Leg Screw Cap x 1 04069009
 Hardware D   Leg Cover x 1 04069006 (Set)	 Hardware C   6mm Allen Wrench x 1 04069005
 Hardware E   Leg Cover x 1 04069006 (Set)	 Hardware H   4mm Allen Wrench x 1 0447162
Casters (Attached) x 4 04069007	



The assembly of this table requires the assistance of another person.



NOTE: Hardware packs are included in packaging. You may receive more hardware than needed. Discard any extra hardware after assembly.

## ASSEMBLY

1. Place the top ③ face down on a protected flat surface so threaded inserts are facing up.
2. Place the legs (parts ① & ②) on top of the threaded inserts in the top.

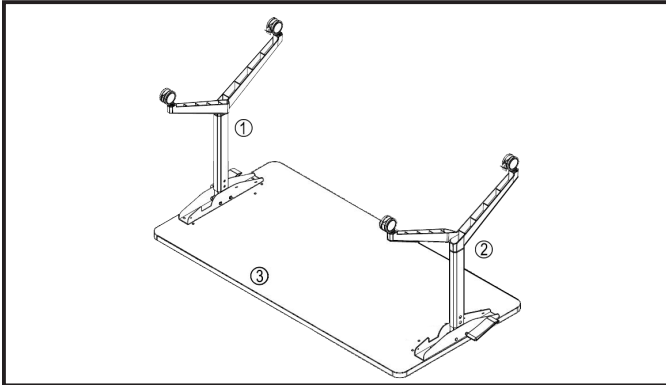

3. Align the flip mechanism rod ④ with the flip mechanism pin on the legs.

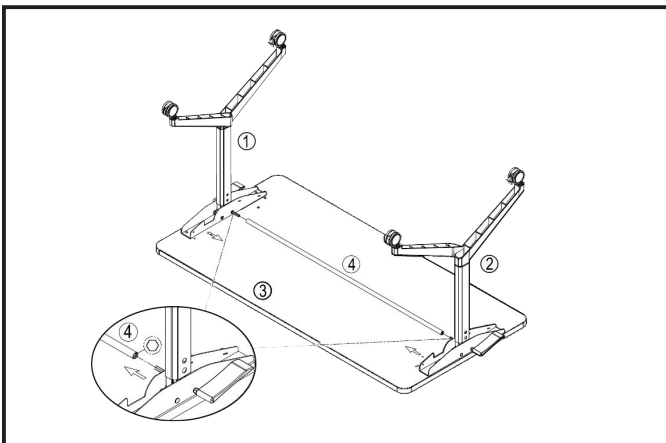

4. Insert hardware F into the stretcher bar ⑤ and twist clockwise until secure.
5. Using hardware A, secure stretcher bar ⑤ to the legs with the included 6mm Allen wrench (C).
5. Place hardware G over hardware A, into the legs.

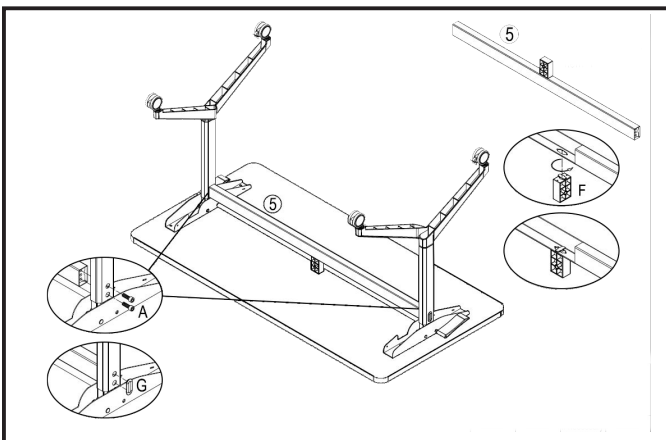

6. Using a 4mm Allen wrench (H) or 4mm hex bit, fasten legs to top with 1/4"-20x19mm joint connector bolts.
7. Snap hardware D & E over legs as shown in image.

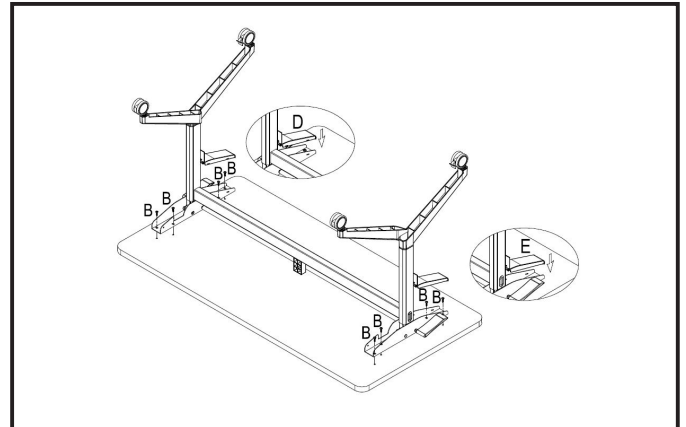

7. With assistance, turn table upright. Push flipping handle to release the flip function.

