



800-242-2303
 wibenchmfg.com
 Part# 0600041



EINSTEIN STATION

 NOTE: Before you begin, please make sure all parts and proper quantities are included. Any parts damaged during shipment must be reported within 24 hours of receipt. To report information regarding damages or if you have any questions, please call 800.242.2303.

 NOTE: These instructions are based on model #ESW6071-30. These instructions work for all Einstein Stations. Product images are for illustrative purposes only and may differ from actual product.

TOOLS NEEDED



Drill

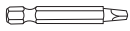

#2 Square Bit



Assistance

PARTS

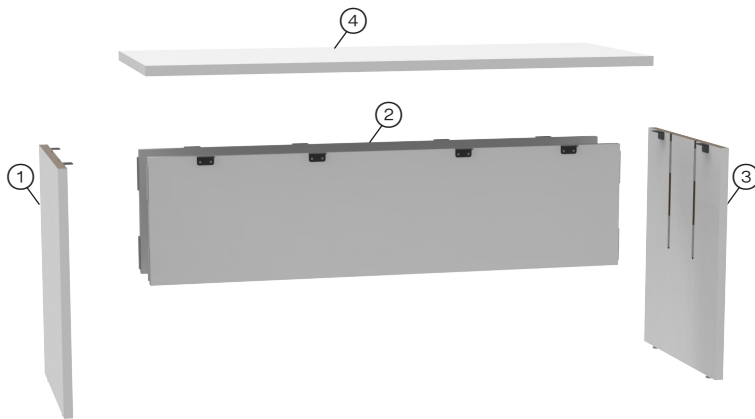

PARTS x QTY

#	DESCRIPTION x QTY
1	Left leg x 1
2	Modesty Panel x 1 or 2 Based on Model
3	Right leg x 1
4	Top x 1

HARDWARE x QTY

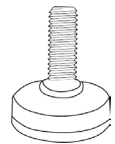

Hardware A x 4
 Screw in Nylon Glide
 0406510

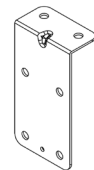

Hardware B x 5
 4" L-Bracket
 0400900

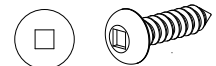

Hardware C x 34
 #10x³/₄" black
 square pan screw
 0406711

Quantities of hardware may vary based on model number of Einstein Station ordered.



The assembly of this desk requires the assistance of another person.



NOTE: Hardware packs are included in packaging. You may receive more hardware than needed. Discard any extra hardware after assembly.

ASSEMBLY

1. Screw **Hardware A** into the metal inserts in the bottom of **Part ①**.

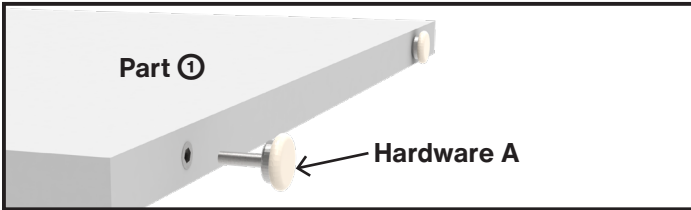

2. Attach (2) **Hardware B** to the inner side of the **Part ①** aligning them with the pre-drilled holes using **Hardware C**. Tighten with a #2 square drive screw driver or a #2 square bit with a screw gun.

Repeat this step for **Part ③**.

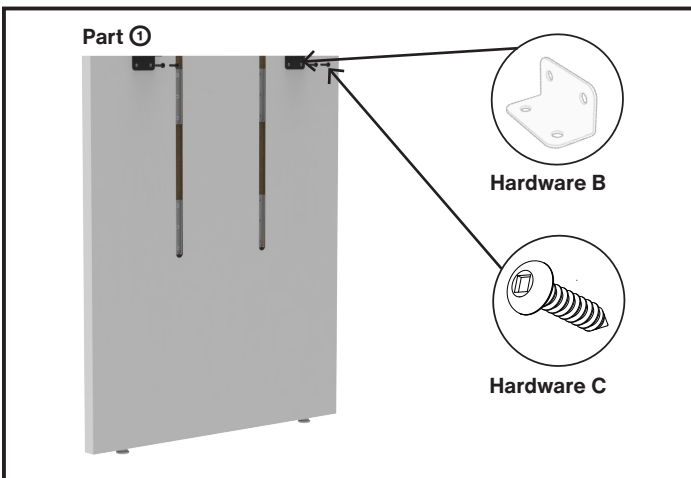

3. Attach (4) **Hardware B** to the outer side of **Part ②** aligning it with the pre-drilled holes using **Hardware B**. Tighten with a #2 square drive screw driver or a #2 square bit with a screw gun.

Repeat this step for **Part ②** (if applicable).

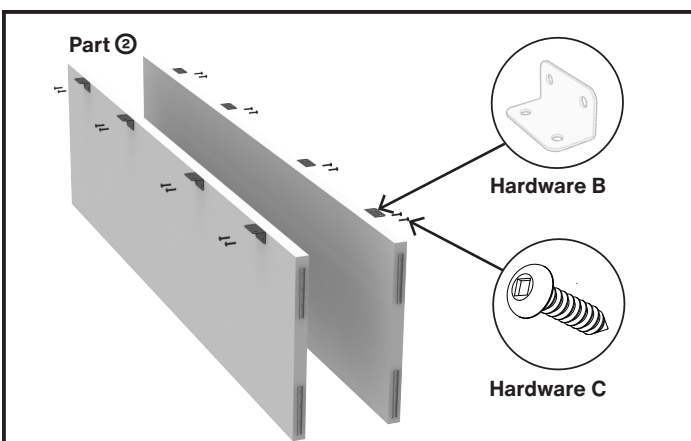

4. While one person holding **Part ①** and another the **Part ③**, you will need to align connectors on the left and right ends of **Part ②** with the connectors on the left and right legs. Press down on the modesty panel until it's fully engaged.

Repeat this step for the other modesty panel if it's double sided.

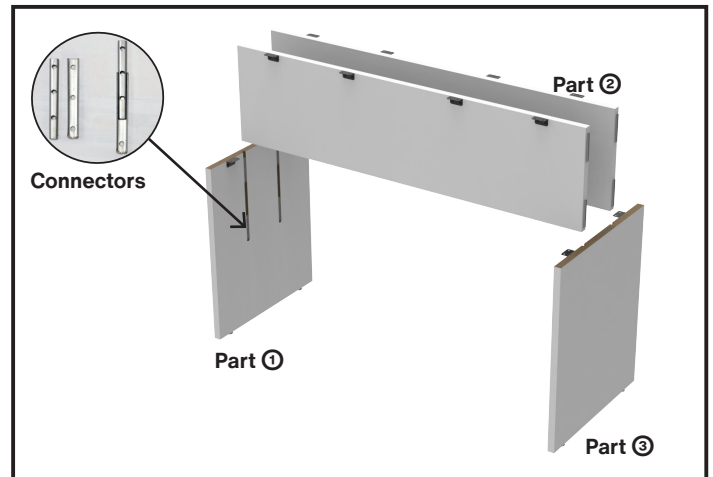

5. Place **Part ④** on **Parts ①, ② & ③**. Align bottom of **Part ④** that has the pre-drilled holes to the brackets that are located on **Parts ①, ② & ③**. Attach **Hardware B** to **Part ④** with (2) **Hardware C**. Tighten with a #2 square drive screw driver or a #2 square bit with a screw gun.

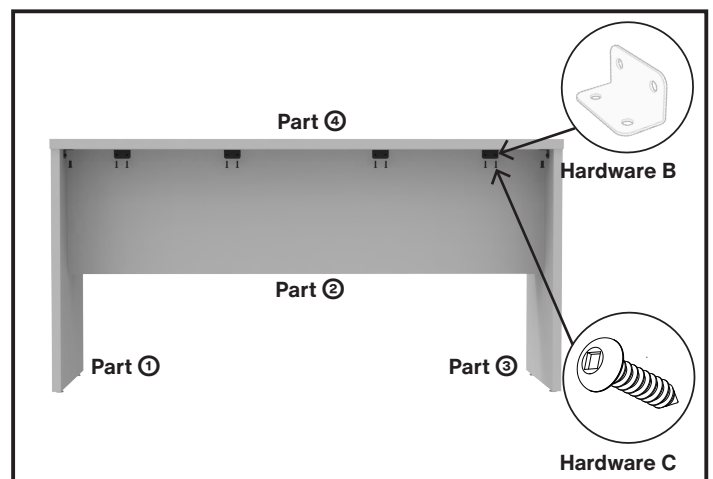

6. Place cable grommets into the holes located on the laminate top, if applicable.



800-242-2303
wibenchmfg.com
Part# 0600014



EINSTEIN STATION

 **NOTA:** Antes de comenzar, asegúrese de que estén incluidas todas las piezas y las cantidades adecuadas. Cualquier pieza dañada durante el envío debe informarse dentro de las 24 horas posteriores a la recepción. Para reportar información sobre daños o si tiene alguna pregunta, llame al 800.242.2303.

 **NOTA:** Estas instrucciones se basan en el modelo #ESW6071-30. Estas instrucciones funcionan para todas las estaciones Einstein. Las imágenes del producto son sólo para fines ilustrativos y pueden diferir del producto real.

HERRAMIENTAS NECESARIAS

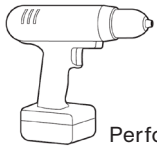

Perforar

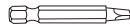

#2 Broca cuadrada



Asistencia

PARTES

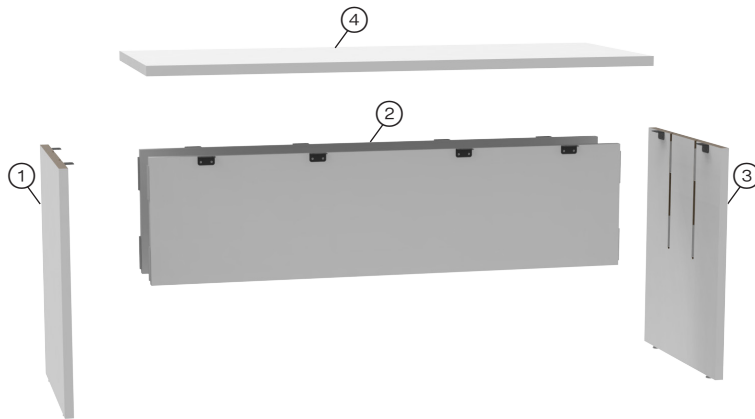

PIEZAS

#	DESCRIPCIÓN x CANTIDAD
1	Pierna izquierda x 1
2	Panel de modestia x 1 or 2 Dependiendo del modelo
3	Pierna derecha x 1
4	Arriba x 1

HARDWARE x CANTIDAD

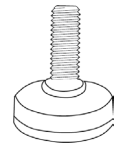

Herraje A x 5

Atornille el deslizador de nailon
0406510

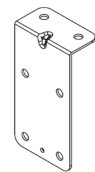

Herraje B x 5

Soporte en L de
4"0400900

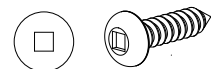

Herraje C x 34

#10x³/₄" tornillo
0406711



El montaje de este escritorio requiere la asistencia de otra persona.



NOTA: Los paquetes de hardware están incluidos en el paquete. Es posible que reciba más hardware del necesario. Deseche cualquier hardware adicional después del montaje.

ASSEMBLY

1. Atornille el Hardware A en los insertos metálicos en la parte inferior de la Parte ①.

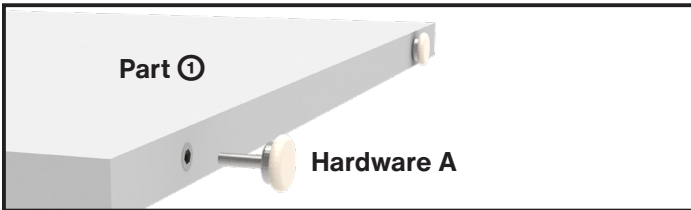

2. Coloque (2) herrajes B en el lado interior de la pieza ① alineándolos con los orificios pretaladrados usando los herrajes C. Apriete con un destornillador de punta cuadrada n. (2) o una punta cuadrada n. (2) con una pistola atornilladora.

Repita este paso para la pierna derecha.

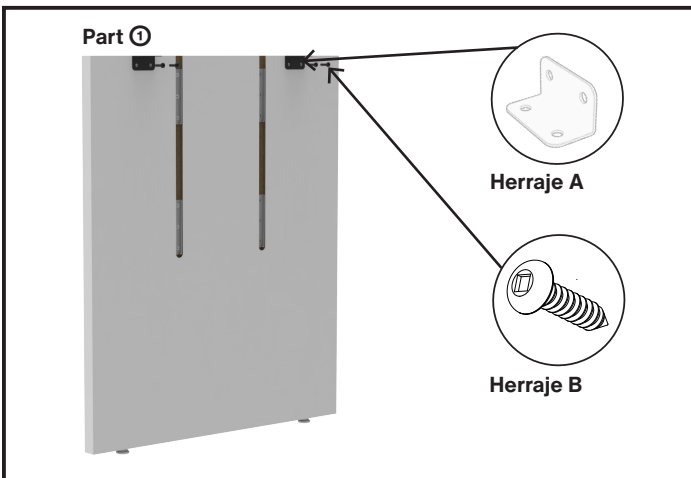

3. Conecte los (4) elementos metálicos B al lado exterior de la pieza ② alineándolos con los orificios previamente perforados utilizando los elementos metálicos C. Apriete con un destornillador de punta cuadrada n. (2) o una punta cuadrada n. (2) con una pistola atornilladora.

Repita este paso para el otro panel de modestia (si corresponde).

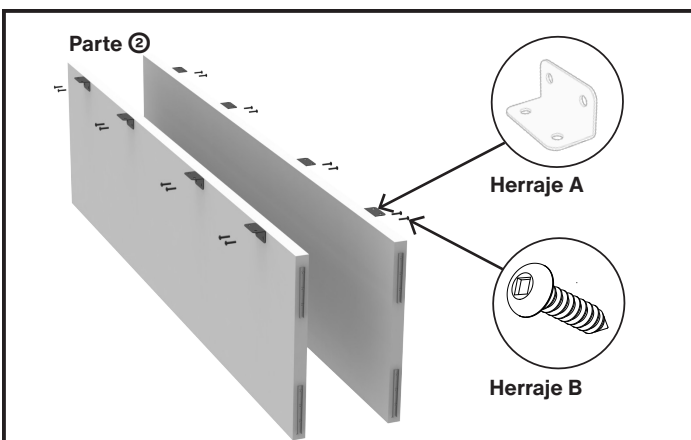

4. Mientras una persona sostiene la Parte ① y otra la Parte ③, deberá alinear los conectores en los extremos izquierdo y derecho de la Parte 2 con los conectores en las patas izquierda y derecha. Presione hacia abajo el panel modesto hasta que esté completamente enganchado.

Repita este paso para el otro panel modesto si es de doble cara.

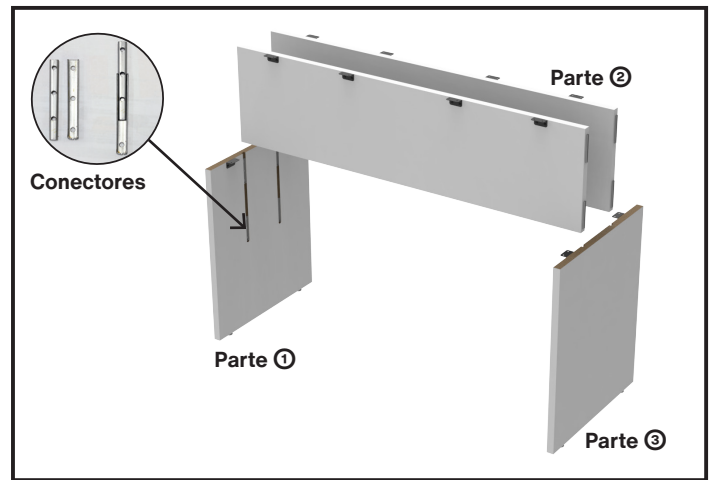

5. Coloque la pieza ④ sobre las piezas ①, ② y ③. Alinee la parte inferior de la Parte ④ que tiene los orificios previamente perforados con los soportes que se encuentran en las Partes ①, ② y ③. Conecte el hardware A a la pieza ④ con (2) hardware C. Apriete con un destornillador de punta cuadrada n. (2) o una punta cuadrada n. (2) con una pistola atornilladora.

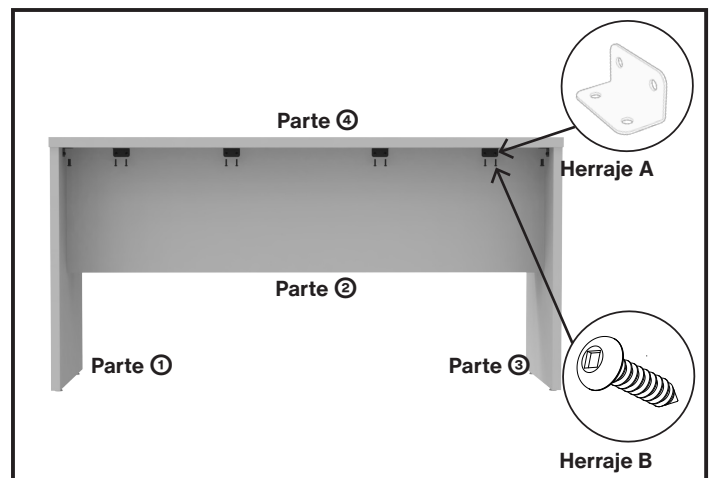

6. Coloque pasacables para cables en los orificios ubicados en la parte superior laminada, si corresponde.