

# Assembly Instructions

## Café Tables



Before you begin, please make sure all parts and proper quantities are included. (See Part Identifier Key) Any parts damaged during shipment must be reported within 24 hours of receipt. To report information regarding damages or if you have any questions, please call 800.242.2303.

### Step 1:

- Place table top face down on protected flat surface so threaded inserts are facing up.

### Step 2:

- Align base with threaded inserts
- Using a 4mm Allen wrench or 4mm hex bit, secure top with joint connector bolts. (See Part Identifier Key for type of bolt to go with the base.)

### Steps 1-2

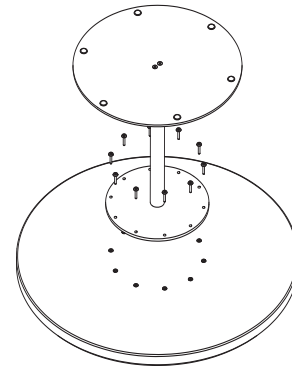

# Assembly Instructions

## Café Tables

w/ Flip Top

Before you begin, please make sure all parts and proper quantities are included. (See Part Identifier Key) Any parts damaged during shipment must be reported within 24 hours of receipt. To report information regarding damages or if you have any questions, please call 800.242.2303.

### Step 1:

- Place table top face down on protected surface so threaded inserts are facing up.

### Step 2:

- Remove all the parts for the Flip table from the box.
- Open flip mechanism up. (See image to the right.)
- Place the mechanism on the table top making sure you align the holes with with threaded inserts in the table top.
- Using a 4mm Allen wrench or 4mm hex bit and screw gun, secure mechanism to table top with joint connector bolts. (See part identifier key for type of bolt needed for the base type.)

### Handle Flip Mechanism

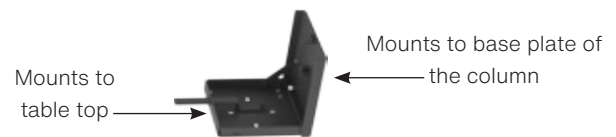

### Steps 1-2

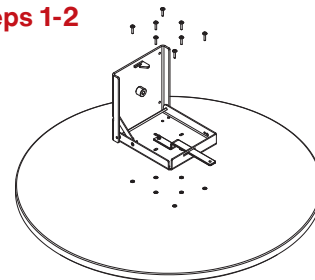

### Tools Required

- Screw gun
- 4mm Allen wrench OR
- 4mm hex bit

**Step 3:**

- Attach the base plate of the column to the flip mechanism with the hardware found in the box.

**Step 4:**

- If feet are not attached to column, follow Instructions that were included in the box to assemble them together.



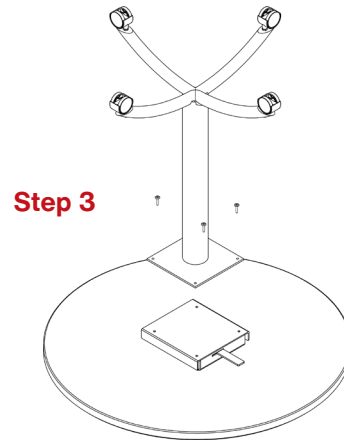

**Step 5:**

- With someone's help, turn table upright.





## Part Identifier Key

### Round Top w/Tubular X-Base (Fixed Height)

Table Dia"	Base #	Base Part #:	Bolt Type (Used to attach base to top)	Bolt Part #	Qty.	
24	7522	040155	1/4"-20 x 15mm joint connector bolt	04009023	8	
30	7526	04066788	1/4"-20 x 15mm joint connector bolt	04009023	12	
36	7526	0401320	10-24 x 1" joint connector bolt	0401158	8	
42	7532	04067469	1/4"-20 x 15mm joint connector bolt	04009023	12	
48	7538	04009320	1/4"-20 x 15mm joint connector bolt	04009023	8	







### Round Top w/Pedestal Base (Fixed Height)

Table Dia"	Base #	Base Part #:	Bolt Type (Used to attach base to top)	Bolt Part #	Qty.	
24, 30, & 36	1844	0409895	10-24 x 1" joint connector bolt	0401158	12	
42 & 48	2244	0402016	1/4"-20 x 15mm joint connector bolt	04009023	12	





### Part Identifier Key

#### Square Top w/Tubular X-Base (Fixed Height)

Table Size"	Base #	Base Part #:	Bolt Type (Used to attach base to top)	Bolt Part #	Qty.	
24x24	7522	040152	10-24 x 1" joint connector bolt	0401158	12	
30x30	7526	0401320	10-24 x 1" joint connector bolt	0401158	8	
36x36	7532	0401322	10-24 x 1" joint connector bolt	0401158	8	
42x42	7538	04009320	1/4"-20 x 15mm joint connector bolt	04009023	12	



#### Square Top w/Pedestal Base (Fixed Height)

Table Size"	Base #	Base Part #:	Bolt Type (Used to attach base to top)	Bolt Part #	Qty.	
24x24, 30x30, & 36x36	1870	04009481	1/4"-20 x 15mm joint connector bolt	04009023	12	
42x42	1871	04067736	1/4"-20 x 15mm joint connector bolt	04009023	12	
48x48	1872	04067865	1/4"-20 x 15mm joint connector bolt	04009023	8	



#### Round Flip Top w/Tubular X-Base (Fixed Height w/Casters)

Table Dia"	Base #	Base Part #:	Bolt Type (Used to attach base to top)	Bolt Part #	Qty.	
30 & 36	FTC7526	0401320	10-24 x 1" joint connector bolt	0401158	8	
48	FTC7538	04009320	1/4"-20 x 15mm joint connector bolt	04009023	8	