



# Assembly Instructions

## Activity Tables

Before you begin, please make sure all parts and proper quantities are included. (See Part Identifier Key) Any parts damaged during shipment must be reported within 24 hours of receipt. To report information regarding damages or if you have any questions, please call 800.242.2303.

**NOTE:** These assembly instructions are for all activity tables, no matter the model or shape. The pre-drilled pilot holes in the worksurface will pre-determine the location the legs will be placed.

### Step 1:

- Place worksurface face down with pre-drilled pilot holes facing up, on a protected flat surface.

### Step 2:

- Align the quick mount leg plates with the pre-drilled pilot holes. Use a  $\frac{5}{16}$ " hex bit and screw gun and #10 x  $\frac{3}{4}$ " square pan screws to secure all of the leg plates to the worksurface.

### Step 3:

- Insert legs into the leg plate as shown in the image to the right. Do this for all legs.

### Step 4:

- Secure the leg to the leg plate using a  $\frac{5}{16}$ " hex bit and screw gun with #10 x  $\frac{3}{4}$ " square pan screws. Do this for all legs.

### Step 5:

- With the help of another person, turn table into the upright position.

### Tools Required

- Screw gun

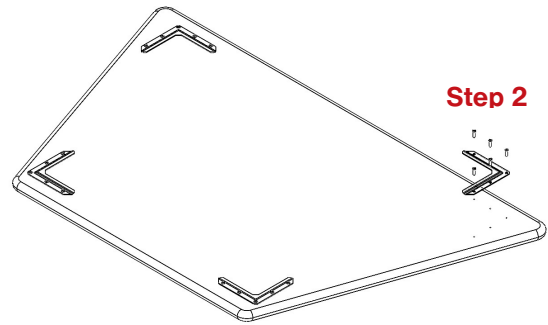

Step 2

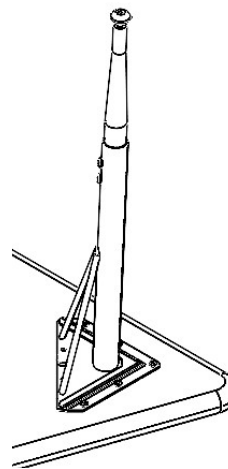

Step 3

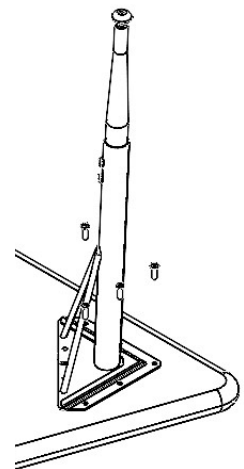

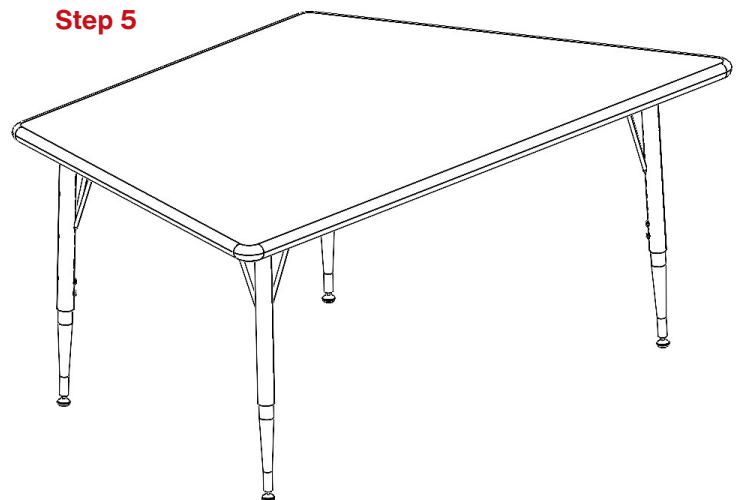

Step 4

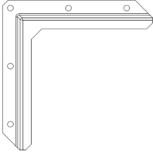

Step 5

### Part Identifier Key

Part #	Description	Qty.	
0406830	Quick Mount Table Bracket	N/A	
0408231	#10 x 3/4 Screw Leg Plate Square Pan	N/A	
0406840	ALS Leg, Adjustable, Black	N/A	